

Industrial Workstation

▶ **AWK - 4630**



▶ FEATURES

- 15" High Brightness TFT LCD (400 cd/m²)
- Heavy-duty rack-mount steel enclosure
- Front panel NEMA 4 & IP65
- Optional Touchscreen
- Lockable door provides protection for unauthorized download data
- Built-in with P4 based full-size industrial-grade Single Board

INTRODUCTION

AWK-4630 is a front panel NEMA 4 & IP 65 industrial Rack-mount PC Workstation with built-in 15" TFT high brightness LCD display(400 nits) .

It has a sealed 59-key membrane keypad and 2-button touchpad pointing device. It gives users an easy way to process data on the plant floor.

AWK-4630 is one of the most reliable Industrial-grade workstations to meet today's requirements for factory automation.



2600 Boyce Plaza Road
Pittsburgh, PA 15241

Phone: 412-257-2620

Fax: 412-257-2649

E-mail: sales@aplexusa.com

[Http://www.aplexusa.com](http://www.aplexusa.com)

AWK SERIES



▶ Industrial Workstation

Display Specifications

AWK - 4630

LCD	15" TFT LCD 1024x768 400 cd/m ²
OSD Control	on/off power switch OSD Key Pads switch Membrane Keypad and touchpad
Interface	Analog VGA input with OSD (on screen display)

System Specifications

CPU	Supports Socket 478 Based P4 processor up to 3.06Ghz CPU (FSB 400/533Mhz)
Memory	Support up to 2Gb SDRAM (184-pin DDR SDRAM)
Ethernet	1 x 10/100 Base-T Ethernet and 1 x Giga Ethernet Controller
Storage Disk Drive	3.5" HDD, FDD, CD-Rom
USB Connector	DUAL USB ports
Membrane Keypads	One with 59 data-keys, one with 12 function keys and 3 programmable function keys
Keyboard / Mouse Connector	PS/2 connector on front panel
Expansion Slot	4xPCI or 4 x ISA and 2 x PICMG
Power Supply	Universal 300W with PFC switching power supply
OS Support	MS Dos, Win 98/SE. XP, 2000

Mechanical Specifications

Construction	Aluminum front panel and heavy-duty steel enclosure
Front Panel Color	Beige
Drive Bays	3 x 5.25" , Designed with an anti-vibration card clamp that keep the system stable
Operating Temperature	0-50°C
Storage Temperature	-10°C - 75°C
Cooling Fans	One 12cm cooling fans; 85 CFM
Vibration	5 - 17HZ, 0,1" double amplitude displacement 17 - 640HZ, 1.5G acceleration peak to peak
Shock	10G acceleration peak to peak (11ms)
EMC	FCC/CE A level certified
I/O Ports	2 serial ports: 1 x RS-232, 1 x RS-232/422/485 (One is reserved for Touchscreen)
Dimension	483(W) x 354(H) x 266(D) mm
Gross Weight	16(Kg)/36lbs

Touchscreen (Optional)

Type	8-wire, analog resistive
Resolution	2048x2048
Light Transmission	75%
Lifetime	1 million activations
OS support	MS DOS, Win 98/SE, 2000, XP, Linux 8.0

AWK-4630

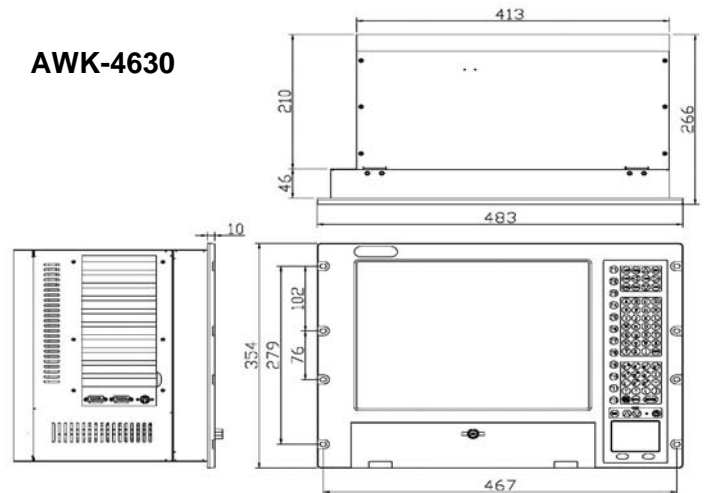

Note: All specifications are subject to change without notice.



Phone: 412-257-2620
 Fax: 412-257-2649
 E-mail: sales@aplexusa.com
 Http://www.aplexusa.com

2600 Boyce Plaza Road
 Pittsburgh, PA 15241